

## Quick Start Guide



for dishwashers





**These short instructions are not a substitute for the operating instructions supplied with the appliance.**

Please read the operating instructions supplied with your dishwasher before using it for the first time and take note of the Warning and Safety instructions, as well as the full descriptions on how to use your appliance.

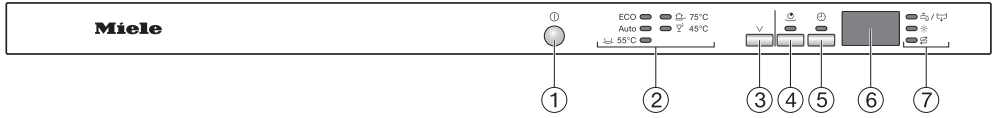
en-AU, NZ

# Guide to the appliance



- ① On/Off button ①
- ② Programme selection  
 ECO = ECO  
 Auto = Automatic  
 55°C = Light soiling 55°C  
 75°C = Intensive 75°C  
 45°C = Gentle 45°C
- ③ Programme selector button ∨
- ④ Short button  with indicator light
- ⑤ Delay start button  with indicator light
- ⑥ Display
- ⑦ Check/Refill indicators  
 = Inlet/Drain  
 = Rinse aid  
 = Salt

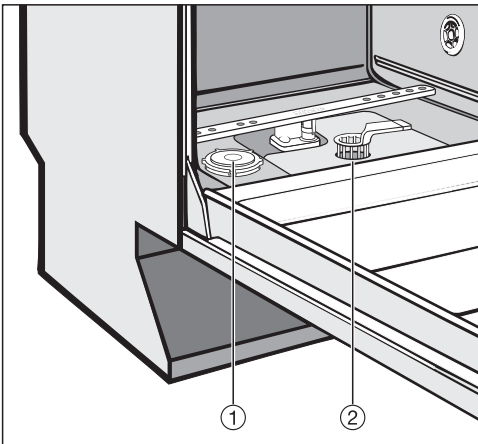

- ① Salt reservoir
- ② Filter combination

# Brief instructions

## ❶ Filling the salt reservoir ↻

- Remove the lower basket and unscrew the salt reservoir cap.

Water or saline solution will run out of the reservoir when the cap is removed.

It should therefore only be removed in order to refill the salt reservoir.

⚠ Dishwasher detergent will damage the water softener.  
Do not fill the salt reservoir with powder or liquid detergent.

- Fill the reservoir with approx. 2 litres of water (first use only).
- Place the funnel provided over the salt reservoir and carefully fill with dishwasher salt until the reservoir is full.
- Clean any excess salt from around the reservoir opening and then screw the cap on again firmly.
- Immediately after filling the salt reservoir, run the *Gentle 45°C* programme with the *Short* programme option selected and without any crockery in the dishwasher to remove any traces of salt from the cabinet.

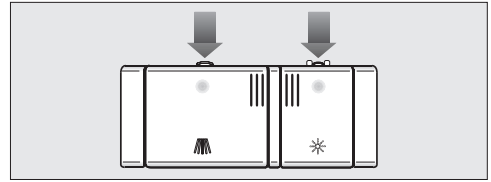

## ❷ Adding rinse aid ✨

- Press the button on the lid of the rinse aid reservoir in the direction of the arrow until the flap springs open.
- Add rinse aid only until it is visible in the opening.
- Close the flap firmly. It should click into place.
- Wipe up any spilled rinse aid. This prevents over-foaming occurring during the next programme.

## ❸ Load the dishwasher

## ❹ Adding detergent 🧼

- Follow the dosage recommended by the manufacturer on the packaging.
- Press the opening catch on the detergent dispenser. The flap will spring open.

The flap is always open at the end of a programme.

- Add the required amount of detergent and close the flap.

## 5 Switching on the dishwasher

- Turn on the tap if it is turned off.
- Open the door.
- Switch the dishwasher on with the  button.

## 6 Selecting a programme

- Use the programme selector button to select the programme required.

## 7 Selecting the Short programme option (if required)

The  button is used to select the Short programme option.

The option selected will remain active for that particular programme until the setting is changed.

- Press the  button.

The  indicator light comes on.

## 8 Activating Delay start (if required)

- Set the required time using the  button.

## 9 Starting the programme

- Start the programme by closing the door.

## 10 At the end of a programme - Switching off

A buzzer will sound at the end of the programme with the door closed.

The programme has finished when  appears in the display.

The drying fan may continue to run for a few minutes at the end of the programme.

- Switch the dishwasher off with the  button.

 To prevent the risk of steam damage to the worktop edging above the dishwasher, it is advisable to leave the door closed until you are ready to unload the crockery. Alternatively you can open the door fully until the crockery is cool enough to unload. Do not leave the door only partially open.

## 11 Unloading the dishwasher

Dishes tend to break and chip more easily when they are hot. Allow the dishes to cool until they are comfortable enough to handle before unloading them.

## Cleaning and care

### Checking the filters in the wash cabinet

**!** This dishwasher must not be used without all the filters in place.

- Check the condition of the filters regularly and clean them if necessary.

### Cleaning the filters

- Switch the dishwasher off.

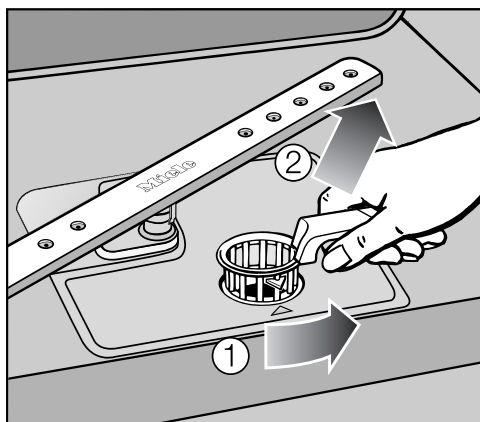

- Turn the handle anti-clockwise to release the filter combination ①.
- Lift the filter combination out of the dishwasher ②. Remove any coarse particles and rinse the filter well under running water. Use a nylon brush if necessary.

**!** Ensure that coarse soil doesn't get into the circulation system and cause a blockage.

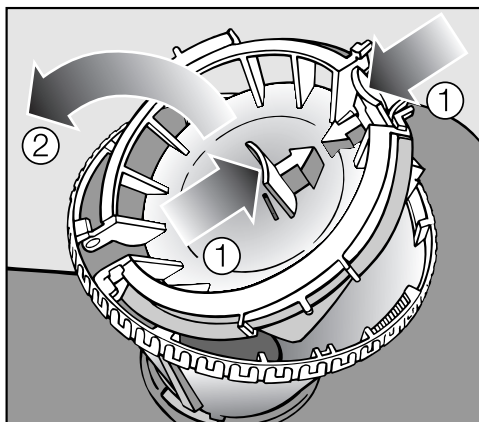

To clean the inside of the filter, the flap must be opened:

- Press catches ① together in the direction of the arrows as shown, and open the filter ②.
- Rinse all the filters under running water.
- Then close the flap so that the catch engages.
- Replace the filter combination so that it lies flat in the base of the wash cabinet.
- Then turn the handle clockwise until both arrows point towards each other. This will lock the filter combination in place.

## Cleaning the spray arms

Particles of food can get stuck in the spray arm jets and bearings. The spray arms should therefore be inspected and cleaned regularly (approx. every 4 - 6 months).

- Switch the dishwasher off.

Remove the spray arms as follows:

- Take out the cutlery tray (if your dishwasher is fitted with one).
- Push the **top** spray arm upwards to engage the inner ratchet. Then unscrew the spray arm.

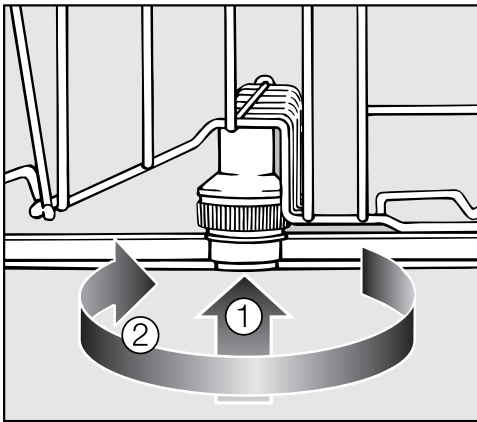

- Push the **middle** spray arm upwards ① to engage the ratchet. Then unscrew the spray arm ②.
- Remove the lower basket.

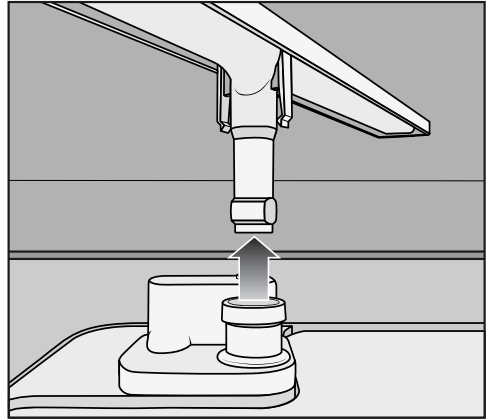

- Pull the **lower** spray arm firmly upwards to remove it.
- Use a pointed object to push food particles into the spray arm jets.
- Rinse thoroughly under running water.
- Refit the spray arms and check that they rotate freely.

# Programme chart

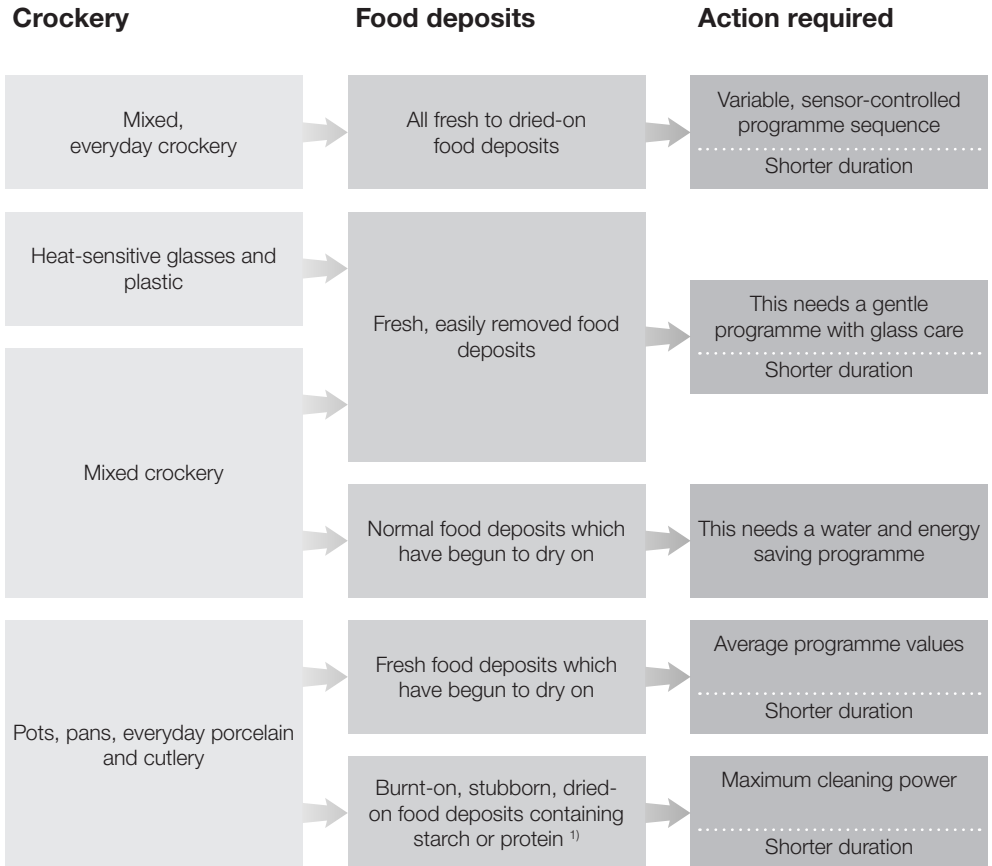

<sup>1)</sup> Food such as potatoes, pasta, rice or stews can leave starchy deposits. Deposits containing protein can be left by food such as fried meat, fish or eggs and bakes.

Programme	Detergent	
	Compartment I <sup>2)</sup>	Compartment II <sup>2)</sup>
<b>Automatic</b> ----- <b>+short</b>	-	25 ml or 1 tab
<b>Gentle 45°C</b>  ----- <b>+short</b>	-	20 ml or 1 tab
<b>ECO</b>	-	25 ml or 1 tab
<b>Light soiling 55°C</b> ----- <b>+short</b>	-	25 ml or 1 tab
<b>Intensive 75°C</b> ----- <b>+short</b>	10 ml	25 ml or 1 tab

<sup>2)</sup> see "Detergent"